

Non-contact infrared thermometer

1420 Instruction manual

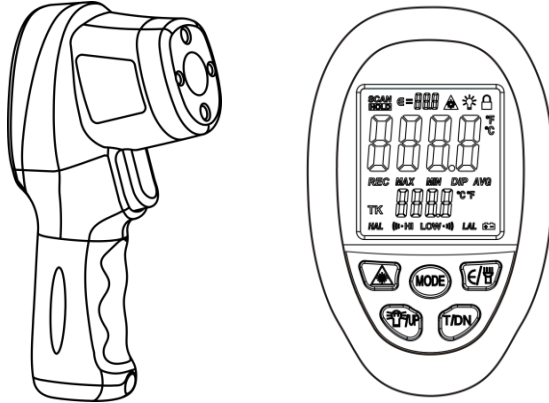

1、 Introduction

Compact, rugged and easy to use. Just aim and push the button, read current surface temperatures in less than a second. Safely measure surface temperatures of hot, hazardous or hard-to-reach objects without contact.

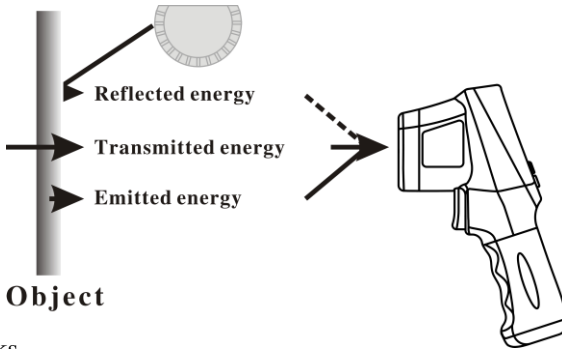

How it works

Infrared thermometer measures the surface temperature of an object. The unit's optics sense emitted, reflected, and transmitted energy which is collect and focused onto a detector. The unit's electronics transmitted energy which is display on the unit. For increased ease and accuracy the laser pointer makes aiming even more precise.

Cautions

Infrared thermometer should be protected for the following:

- EMF(electro-magnetic fields) from arc welders, induction heaters.
- Thermal shock(cause by large or abrupt ambient temperature changes allow 1 hours for unit to stabilize before use).

--Do not leave the unit on or near objects of high temperature.

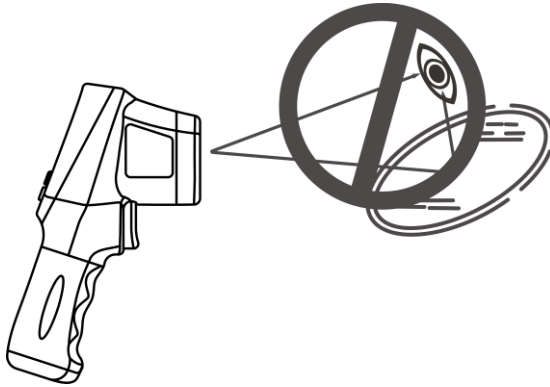

Warning

Do not point laser at eye or indirectly off reflective surfaces.

1. When take measurement, point thermometer toward the object to be measured and hold the yellow trigger. The object under test should be large than the spot size calculated by the field of view diagram.
2. Distance & spot size: As the distance from the object increase, the spot size of measuring area becomes large.

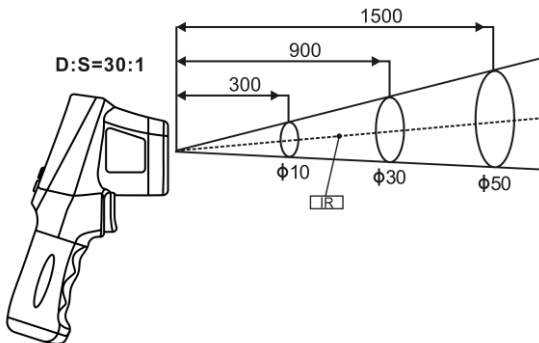

3. Field of view: Make sure the target is larger than the unit's spot size. The smaller the target the close measure distance. When accuracy is critical, make sure the target is at least twice as large as the spot size.
4. Emissivity: Most organic materials and painted or oxidized surfaces have an emissivity of 0.95. Inaccurate readings will result from measuring shiny or polished metal surfaces. To compensate, cover the surface to be measured with masking tape or flat black paint. Measure the tape or painted surface when the tape or painted

reach the same temperature as the material underneath.

2、 Quick start instruction

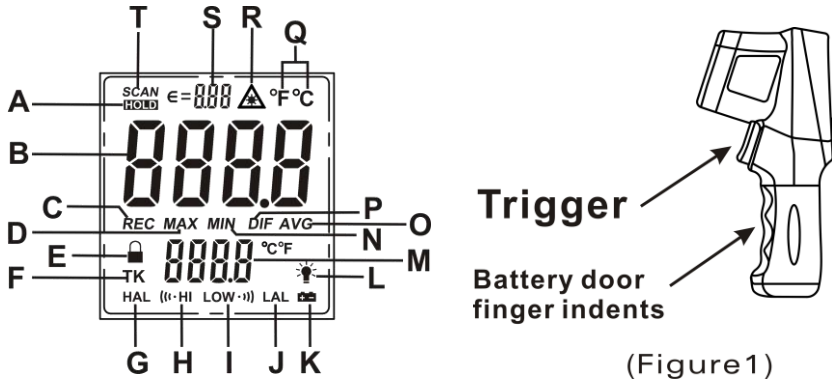

(Figure1)

1. Remove the silica gel set, remove the battery cover screw with a screwdriver, and then slide out the battery door, install battery correctly. And Put back to the battery door screws and silica gel .Pull the trigger, LCD display reading & battery icon. Release the trigger and the reading will hold for 30 seconds.

LCD display:

- A Data Hold
- B Main display value
- C Memory storage
- D Maximum
- E Continuous measurement
- F K type temperature symbol (this unit Without this feature)
- G High temperature alarm temperature
- H Alarm of high temperature prompt
- I Alarm of Low temperature prompt
- J Low temperature alarm temperature
- K Battery voltage Low
- L Backlight symbol
- M Additional features
- N Minimum
- O Average
- P The maximum and the minimum difference
- Q Temperature of the unit
- R Laser pointer turn on prompt
- S Emissivity symbol
- T Measuring the symbol

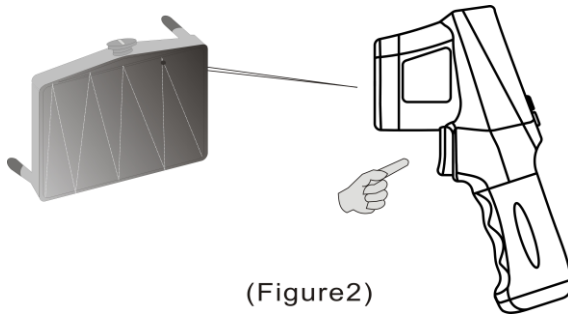

(Figure2)

2. Locating a hot spot aim the thermometer outside the area of interest, then scan across with up and down motions until you locate the hot spot.(please turn on the laser to for accurate measuring)
3. Diagram description

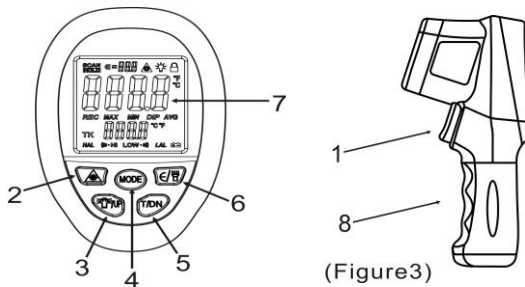

(Figure3)

- (1) Trigger : Press for turn on, and then display test result and hold data automatically(display HOLD) after unclamping switch. Trun off automatically after 30 seconds without operate.
- (2) Laser pointer button : press it display “ \triangle ” for turn on laser pointer, press again for turn off.
- (3) Back light/UP button : When product working, press it for turn on back light, press again for turn off. the second functian please see (4)
- (4) MODE button: Press MODE button for cycle options MAX – MIN-DIF- AVG - HAL– LAL mode.
 - A、 MAX: Measure maximum data current;
 - B、 MIN: Measure minimum data current; ;
 - C、 AVG: Calculate the average of all measure data;
 - D、 HAL/LAL: HAL is Alarm of high temperature. LAL is Alarm of low temperature. Option Alarm of temperature mode, press “Back light/UP” button for

up alarm temperature. press“T/DN”button for down alarm temperature. When LCD display ” (HI” means measure result exceeded the alarm temperature; When LCD display ” LOW “) ” means measure result under the alarm temperature

(5) T/UP button: When product working, press direct for °C/ °F select. second function please see (4).

(6) E/ button: When product working, press direct into set Emissivity mode, press “Back light/UP” button for up Emissivity . press “T/DN” button for down Emissivity. Long press the button, the head lamp lighted.

(7) LCD

(8) Battery door: When replace battery , please to pull open the silicon rubber case ,take off the screw ,then slide open the battery door.

The diagram below operation:

1. Use the screwdriver to unscrew the bottom screw;

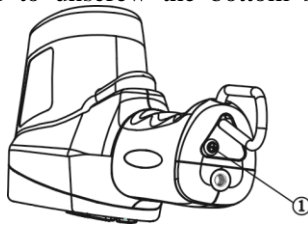

2. Catch the hook and pull the cover of battery out from the bottom;

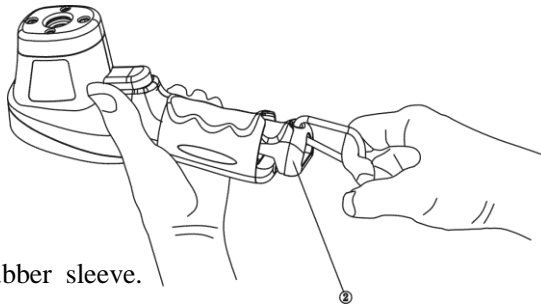

3. Take off the rubber sleeve.

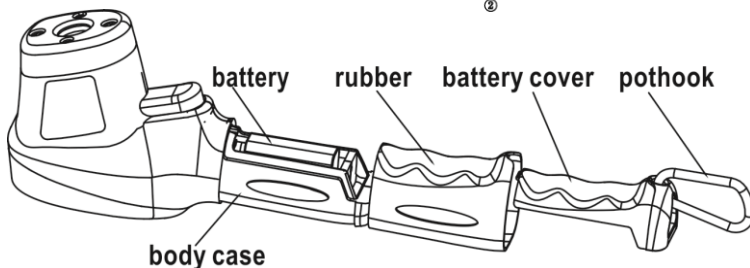

4. Replae the battery and put the rubber sleeve and the cover back.

3、Maintenance

- 1) Lens cleaning: Blow off loose particles using clean compressed air. Gently brush remaining debris away with a moist cotton cloth.
- 2) Case cleaning: Clean the case with a damp sponge/cloth and mild soap.
- 3) Please take out the battery when not using for a long time.

Note:

- 1) Do not use solvent to clean lens.
- 2) Do not submerge the unit in water.
- 3) Emissivity will back to the initial value (0.95) after replacing battery,. Should adjust again when use.

4、specifications

Temperature range	HP-1500	-50°C to 1500°C(-58 to 2732°F)
	HP-1420	-50°C to 1420°C(-58 to 2588°F)
	HP-1320	-50°C to 1320°C(-58 to 2408°F)
Accuracy	$\pm 4^{\circ}\text{C}/7.2^{\circ}\text{F}$, -50°C to 0°C (-58 to 32°F) $\pm(2\%$ reading $+2^{\circ}\text{C}/3.6^{\circ}\text{F})$, 0°C above	
distance spot ratio	30:1	
Emissivity	0.1~1.0 adjustable	
Resolution	0.1°C(0.1°F)<1000, 1°C(1°F)>1000	
Repeatability	1% of reading or 1°C	
Response time	<250msec, 95%response	
Spectral response	8-14um	
Operating temperature	0°C to ~40°C(32 to 104°F)	
Storage temperature	-20~60°C(-4~140°F) without battery	
Relative humidity	Operating :10-95%RH; Storage: 10-95%RH	
Ambient temp range of guarantee for accuracy	23°C~28°C	
Weight/dimensions	160g; 192×95×63mm	
Power	9V battery, 6F22 or NEDA 1604	
Battery life	Laser models:12hrs	

Note:

Display above code in normal Ambient temp, probable means this meter was broken.

Attached list : Applicable Emissivity for Different Material (For reference only)

Material	Emissivity	Material	Emissivity
Asphaltum	0.90 to 0.98	Textile (Black)	0.98
Beton	0.94	Human Skin	0.98
Cement	0.96	Soap bubble	0.75 to 0.80
Sand	0.90	Charcoal (powder)	0.96
Soil	0.92 to 0.96	Lacquer	0.80-0.95
Water	0.92 to 0.96	Lacquer (reluster)	0.97
Ice	0.96 to 0.98	Rubber (Black)	0.94
Snow	0.83	Plastic	0.85-0.95
Glass	0.90 to 0.95	Timber	0.90
Ceramic	0.90 to 0.94	Paper	0.70-0.94
Marble	0.94	Chromic oxide	0.81
Gypsum	0.80 to 0.90	Copper Oxide	0.78
Compo	0.89 to 0.91	Iron Oxide	0.78 to 0.82
Brick	0.93 to 0.96	Stainless steel	0.2-0.3

Above picture and content just for your reference. Please be subject to the actual products if anything different or updated. Please pardon for not informing in advance.



1141 Budapest, Fogarasi út 77. 1095 Budapest, Mester utca 34.
Tel.: *220-7940, 220-7814, 220-7959, Tel.: *218-5542, 215-9771, 215-7550,
220-8881, 364-3428 Fax: 220-7940 216-7017, 216-7018 Fax: 218-5542
Mobil: 30 531-5454, 30 939-9989 Mobil: 30 940-1970, 20 949-2688

E-mail: delton@delton.hu Web: www.delton.hu

www.holdpeak.hu